

# EU Series Signal Phase Power Meter User Manual



## Features:

- ⊙ Measure accuracy:  $\pm 0.5\%FS$
- ⊙ Measure parameters: voltage, current, power factor, active power, reactive power, appearant power, Kwh.
- ⊙ Fully isolation for input and output .
- ⊙ Two high & low limit alarm can be set for voltage, current, power factor, active power, reactive power, appearant power and Kwh.
- ⊙ Optional 4-20mA analog output for voltage, current, power factor, active power, reactive power, appearant power.
- ⊙ RS485 communication port, Modbus-RTU communication protocol.
- ⊙ RMS measurement.
- ⊙ Simple operation, with power failure protection of operation status and Kwh.

For your safety, please read following content carefully before you are using our meter!

## Safe Caution

- \* Please read the manual carefully before you use the temperature controller.
- \* Please comply with the below important points.
- ⚠ Warning An accident may happen if the operation does not comply with the instruction.
- ⚠ Notice An operation that does not comply with the instruction may lead to product damage.
- \* The instruction of the symbol in the manual is as below.
- ⚠ An accident danger may happen in a special condition.

## Warning

1. A safety protection equipment must be installed or please contact with us for the relative information if the product is used under the circumstance such as nuclear control, medical treatment equipment, automobile, train, airplane, aviation and equipment etc. Otherwise, it may cause serious loss, fire or person injury.
2. A panel must be installed, otherwise it may cause creepage (leakage).
3. Do not touch wire connectors when the power is on, otherwise you may get an electric shock.
4. Do not dismantle or modify the product. If you have to do so, please contact with us first. Otherwise it may cause electric shock and fire.
5. Please check the connection number while you connect the power supply wire or input signal, otherwise it may cause fire.

## Caution

1. This product cannot be used outdoors. Otherwise the working life of the product will become shorter, or an electric shock accident may happen.
2. When you connect wire to the power input connectors or signal input connectors, the moment of the No.20 AWG (0.50 mm<sup>2</sup>) screw tweaked to the connector is 0.74n.m - 0.9n.m. Otherwise the connectors may be damaged or get fire.
3. Please comply with the rated specification. Otherwise it may cause electric shock or fire, and damage the product.
4. Do not use water or oil base cleaner to clean the product. Otherwise it may cause electric shock or fire and damage the product.
5. This product should be avoid working under the circumstance that is flammable, explosive, moist, under sunshine, heat radiation and vibration. Otherwise it may cause explosion.
6. In this unit it must not have dust or deposit, otherwise it may cause fire or mechanical malfunction.
7. Do not use gasoline, chemical solvent to clean the cover of the product because such solvent can damage it. Please use some soft cloth with water or alcohol to clean the plastic cover.

## I. Ordering Information

- EU801-W-C E \_\_\_\_\_ E: Version
- \_\_\_\_\_ Analog output: Blank: No analog output function C: Analog output(4~20mA)
- \_\_\_\_\_ Basic functions: W: Single phase with RS485 communication and two alarm output
- \_\_\_\_\_ Dimension(mm): 801: 96W×48H×100L 901: 96W×96H×100L
- \_\_\_\_\_ EU series single phase power meter

Model	Alarm	Analog output	Communication	Input range
EU□-W	Two alarm	No	RS485	5Ax450V
EU□-W-C	Two alarm	4~20mA	RS485	

Please note that the former model is EU8-RC18B , EU8-DC18B, EU9-RC18B, EU9-DC18B , the same function with the new models.

## II. Specification

Measure parameters	Voltage, current, power factor, Kwh, appearant power, reactive power, active power
Input impedance	Voltage input impedance: $\geq 300K\Omega(450V)$ Current input impedance: $\leq 0.02\Omega$ (Direct input 0~5A)
Measure range of Direct input	Voltage: AC 6~450V; Current AC 0.015~5A
Display	Dua line LED display
Current ratio	1.0~1999, which can be set freely
Measure accuracy	Voltage: $\pm 0.5\%FS \pm 2$ Digits Current: $\pm 0.5\%FS \pm 2$ Digits
Sampling rate	About 2times per second
Power supply	AC/DC 100~240V
Dielectric	AC 1500V/1min
Communication	RS485 communication port, Modbus-RTU protocol
Analog output	DC4-20mA analog output; Accuracy: $\pm 0.5\%FS$ ; load ability $\leq 600\Omega$
Insulating resistance	100M $\Omega$
Environment	0~50 $^{\circ}C$ , humidity $\leq 85\%RH$
Dimension	801: 96W*48H*100L 901: 96W*96H*100L

## III. Panel Illustration

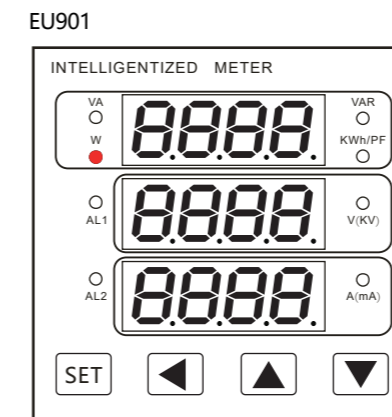
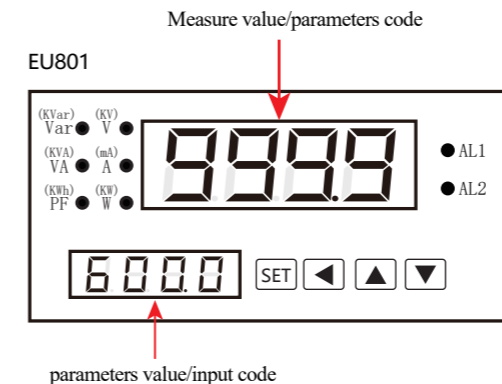

EU801 Panel Illustration

Panel indication	Description
AL1	Alarm 1 #indicator lamp
AL2	Alarm 2 #indicator lamp
KV, V	Voltage V indicator lamp(On light)/KV indicator lamp(Flash)
A, mA	Current A indicator lamp(On light)/mA indicator lamp(Flash)
VAR, KVAR	Reactive power VAR indicator lamp(On light)/KVAR indicator lamp(Flash)
KWh, PF	Power factor PF indicator lamp(On light)/Kwh value indicator lamp(Flash)
W, KW	Active power W indicator lamp(On light)/KW indicator lamp(Flash)
SET	Parameters selection/enter key
◀	Shift key
▲	Decrease key/parameter display
▼	Increase key/parameter display

EU901 Panel Illustration

Panel indication	Description
LED	Display measure value/Parameters setting
AL1	Alarm 1 #indicator lamp
AL2	Alarm 2 #indicator lamp
V (KV)	Voltage V indicator lamp(On light)/KV indicator lamp(Flash)
A (mA)	Current A indicator lamp(On light)/mA indicator lamp(Flash)
VA	Appearant power indicator lamp(On light)/It is KVA when flashing
VAR	Reactive power VAR indicator lamp(On light)/It is KVAR when flashing
KWh, PF	Power factor PF indicator lamp(flash)/Active Kwh value indicator lamp(On light)
W	Active power W indicator lamp(On light)/It is KW when flashing
SET	Parameters selection/Enter key
◀	Shift key
▲	Decrease key
▼	Increase key

# IV. Operation Sequence

EU801 operation sequence

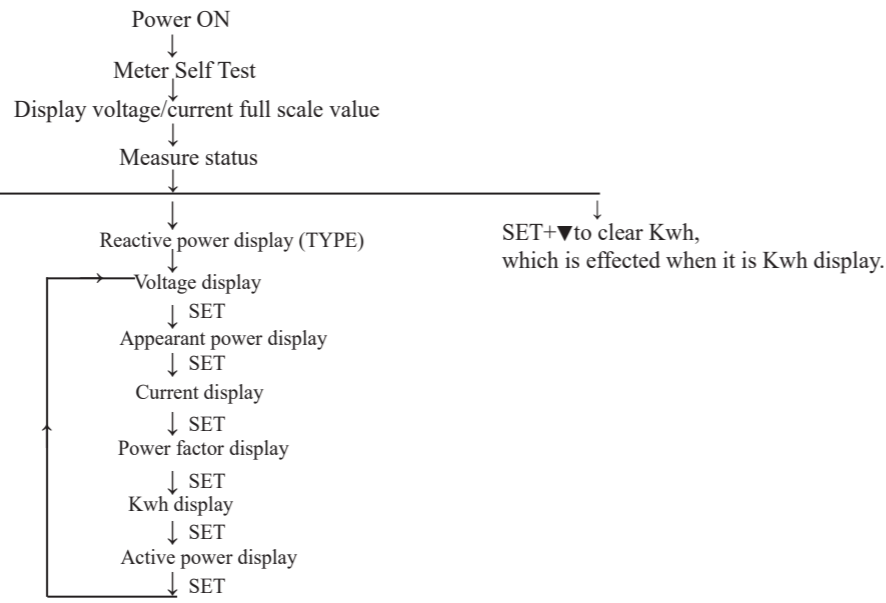

Alarm mode setting

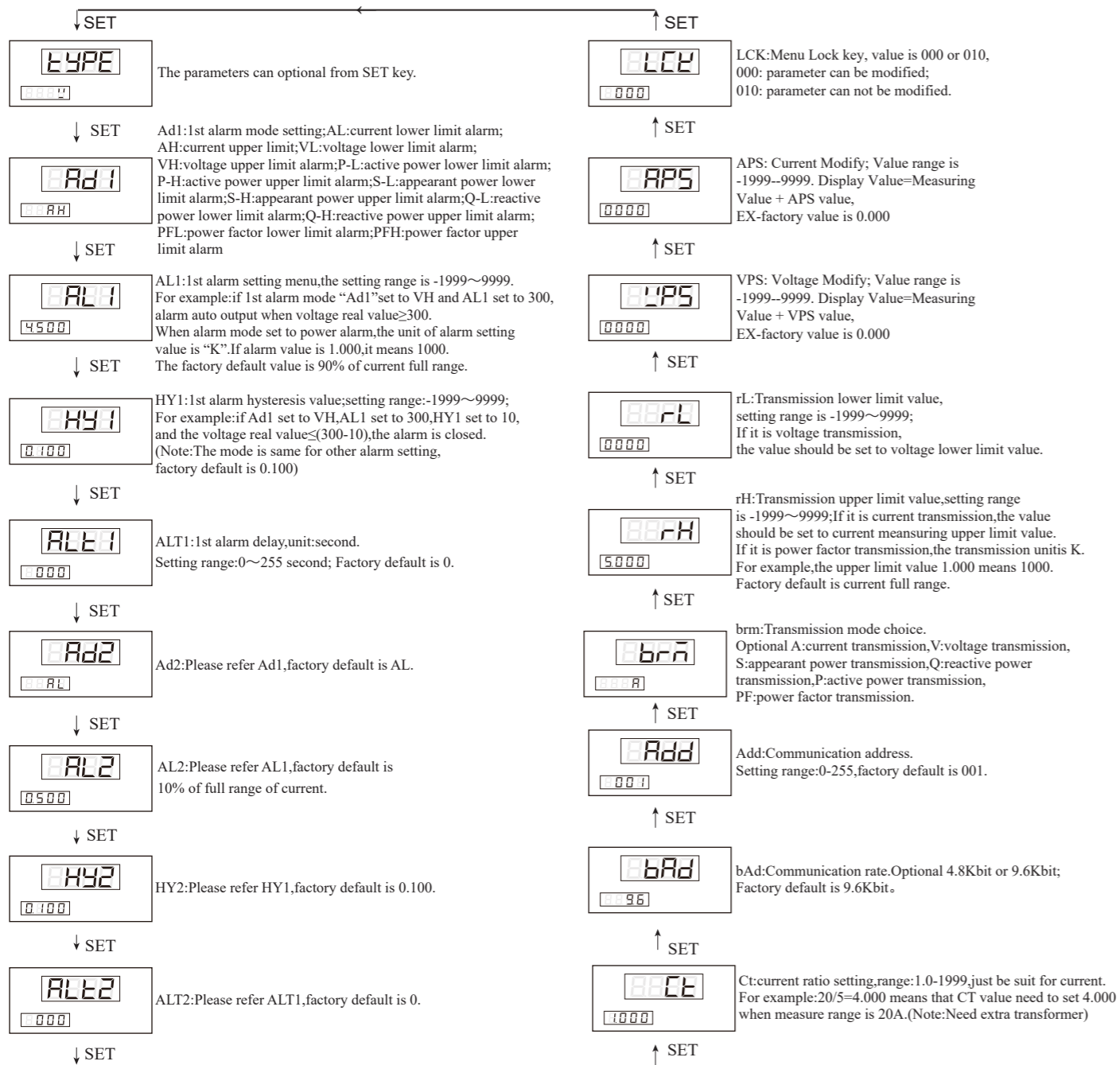

EU901 operation sequence

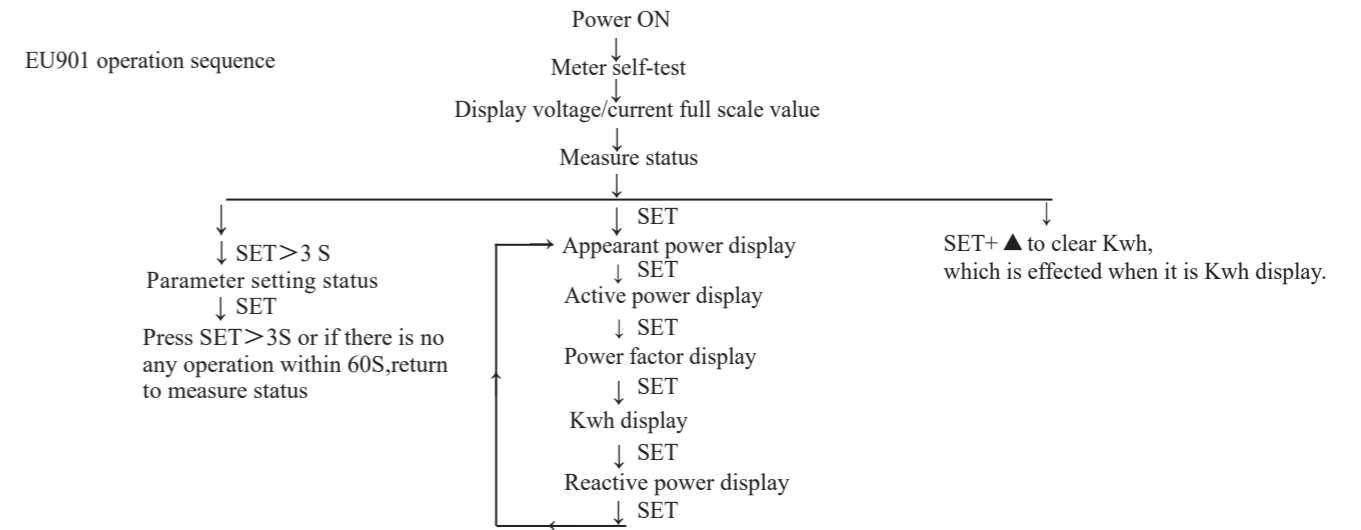

Alarm mode setting

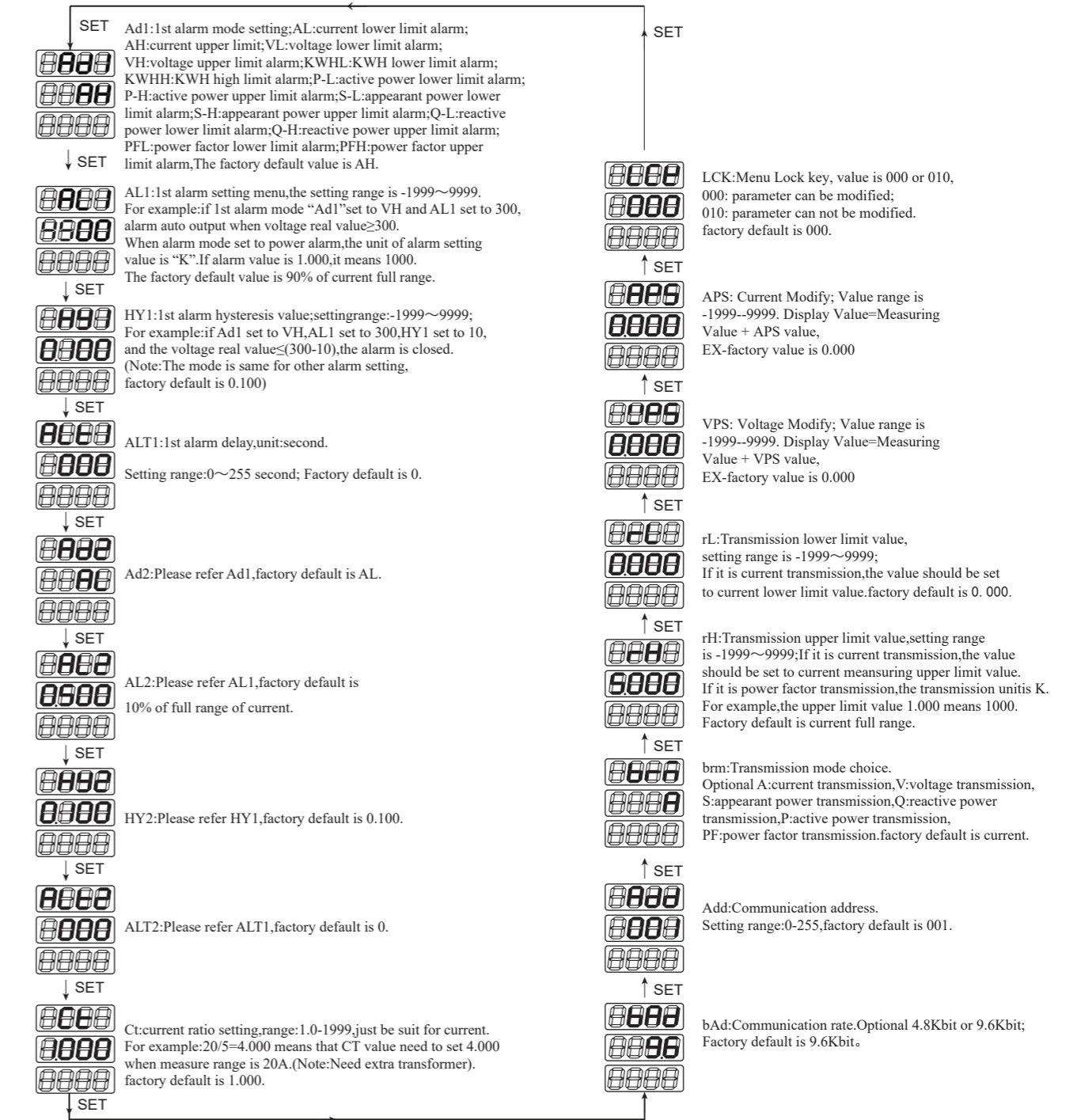

Operation Sequence and Setting Mode Illustration:

1. Press SET key for 3 seconds, enter into parameter setting menu.
2. Press SET key to choose the parameter which need to be modified, press ← key to move the flash light to the value which need to be changed, then press ▼/▲ key to modify the value and press SET key for confirmation. Press ← key and +▲/▼ key at the same time can move decimal point. If just want to turn to the next parameter, just press SET key will be OK.
3. Under the state of modify and setting, press SET key more than 3 seconds, it can return back to the measuring status.
4. Kwh value delete method: In the status of showing Kwh on the main window, press SET key and +▼ key more than 3 seconds at the same time.

Parameter display reference table of each alarm mode

NO	Display Parameter	Upper Limit Alarm	Lower Limit Alarm
1	Ampere	AH	AL
2	Voltage	VH	VL
3	Power Factor	PFH	PFL
4	Reactive Power	Q-H	Q-L
5	Apparent Power	S-H	S-L
6	Active Power	P-H	P-L
7	Kwh	PUHH	PUHL

V. Connections

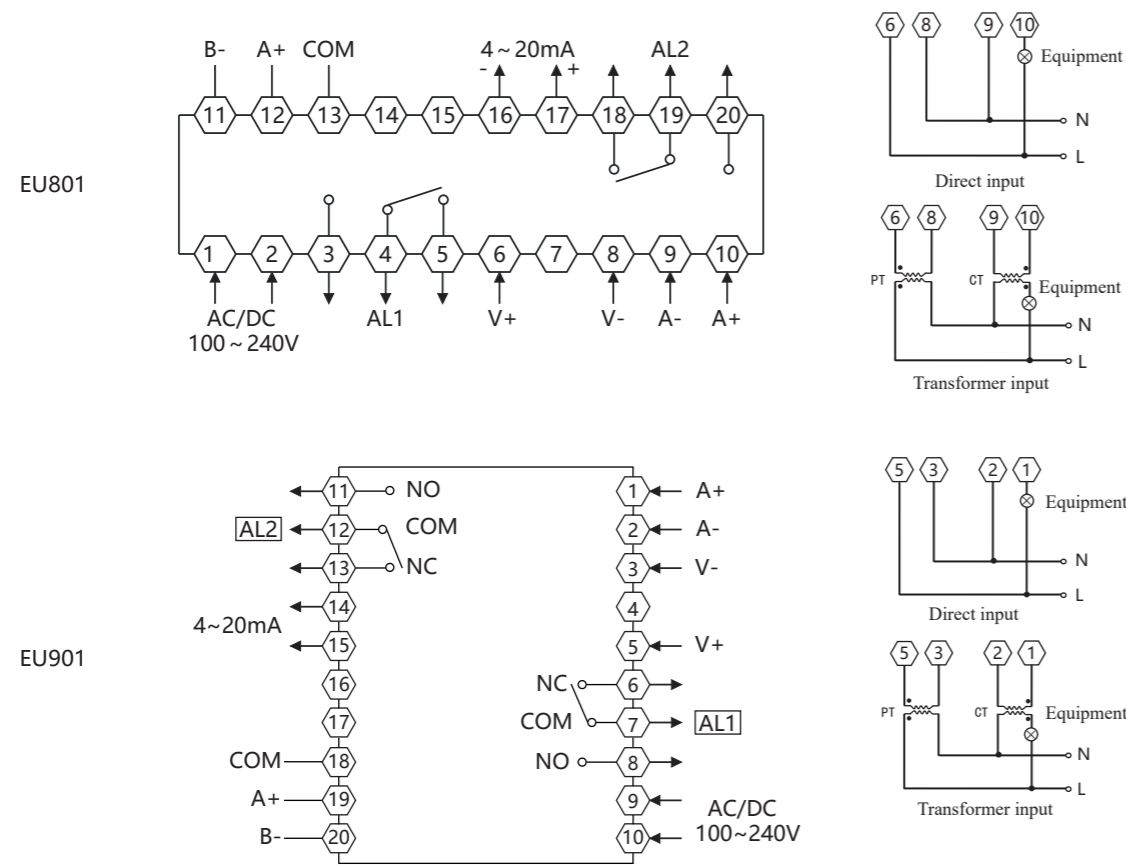

Note:Pls subject to the connection on meter if any difference here.

VI. Dimensions

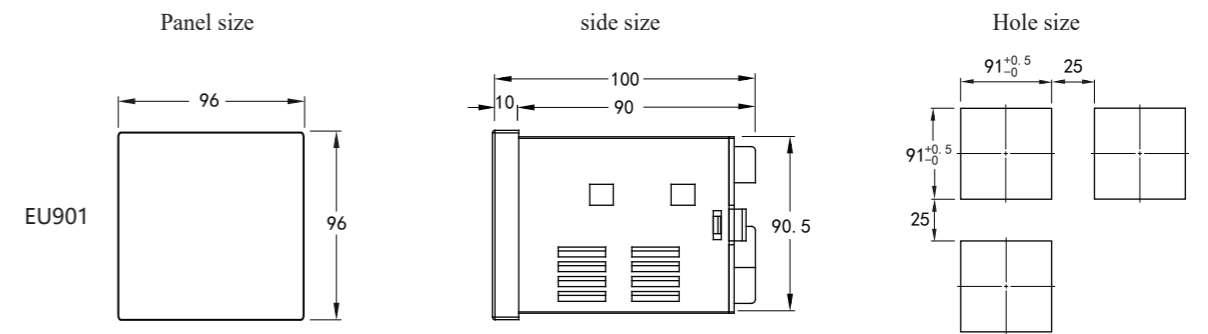
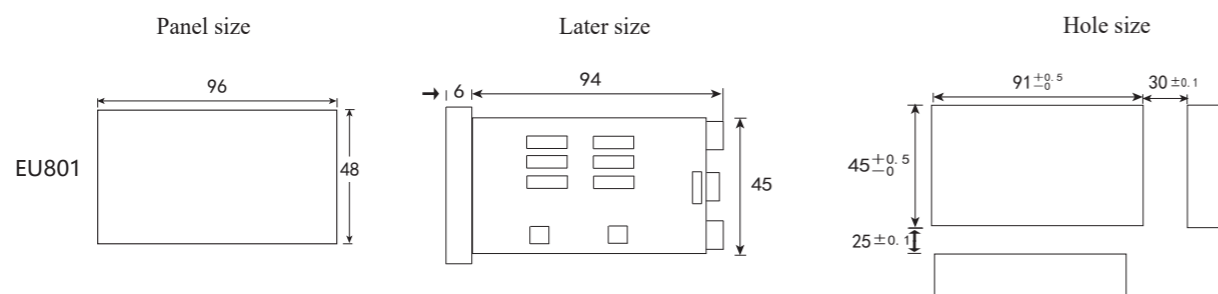

VII. Notice of Preservation

1. Before use, the meter needs to be powered on and preheated for 15 minutes.
2. Appropriate ambient temperature is 0~50 Degree, RH less than 85%
3. Each meter's Calibration interval is one year.
4. Attention to preventing from vibration and shock, keep away from such places:Excessive dust, Excess of harmful chemicals &Excessive harmful chemical gases.
5. Mak sure that the meter powered once every three months if the long-term storage at the end use, and each time's POI not less than 4 hours.
6. Long-term preservation should avoid direct light, the most comfortable storage place with temperature 0 to 50 C ,humidity below 60% R.H. Keep away from organic solvent or oil-exposed .

VIII. Communication Protocol

The meter adopts Modbus RTU communication protocol RS485 half duplex communication , read function code 0x03, write function code 0x10,adopts 16 digit CRC check, the energy meter does not feedback the check error.Communicaton data mode is 32bit integer data,positive number show by original code,negativnumber show by complemental code,data percentage is 0.001.It means that when host receive the meter data 5000,the data multiply by the percentage and then get the original data 5.000. Therefore, when the host writes to the meter, it should also multiply by 1000 and then send it to the meter.

Data frame format:

Start bit	Data bit	Check bit	Stop bit
1	8	NO	1

Handling of communication exception:

If there is abnormal response, put the function ID on the top position 1.For example:Host request the function ID 0x03,and the function ID 0x83 will be back from host.

Type of error code:

0x02 --- Data position error:data position assigned by host is out of the range of meter.

0x03 --- Data value error:data value by host is out of the data range of meter.

CRC check error,function code error,not feedback to value.

1.Read multi-register

For example: The host computer read the float number AL1 (The value of Alarm 1 is 4.5)

The address code of AL1 is 0x0000, 32bit(4 bytes),it occupy 2 data register;16 decimal float of 4.500\*1000=4500 is 0x00001194.

Host request(Read multi-register)							
1	2	3	4	5	6	7	8
Meter ADD	Function ID	Start ADD High bit	Start ADD Low bit	Data byte High bit	Data byte Low bit	CRC code Low bit	CRC code High bit
0x01	0x03	0x00	0x00	0x00	0x02	0xC4	0x0B

Meter normal answer(Read multi-register)								
1	2	3	4	5	6	7	8	9
Meter ADD	Function ID	Data byte number	Data 1 High	Data 1 Low	Data 2 High	Data 2 Low	CRC code Low	CRC code High
0x01	0x03	0x04	0x00	0x00	0x11	0x94	0xF7	0xCC

Function ID abnormal answer:(For example,host request function ID 0x03)

Meter abnormal answer(Read multi-register)				
1	2	3	4	5
Meter ADD	Function ID	Error code	CRC code Low	CRC code High
0x01	0x83	0x02	0xC2	0xC1

2、 Write multi-register

For example: Host write float data AL1 (1st loop alarm value is 5.0)

The ADD code of AL1 is 0x0000,32bit (4 bytes),it occupy 2 data register.16 decimal float of 5.0\*1000=5000 is 0x00001388

Host request(Write multi-register)												
1	2	3	4	5	6	7	8	9	10	11	12	13
Meter ADD	Function ID	Start ADD high	Start ADD low	Data byte length high	Data byte length low	Data byte length	Data 1 high	Data 1 low	Data 2 high	Data 2 low	CRC low	CRC high
0x01	0x03	0x00	0x00	0x00	0x02	0x04	0x00	0x00	0x13	0x88	0xFE	0xF9

Meter normal answer(Write multi-register)							
1	2	3	4	5	6	7	8
Meter ADD	Function ID	Start ADD high 8 bits	Start ADD low 8 bits	Data byte length high	Data byte length low	CRC code low	CRC code high
0x01	0x10	0x00	0x00	0x00	0x02	0x41	0xC8

Data place abnormal answer:(For example,host request write address index is 0x0050)

Meter abnormal answer(Write multi-register)				
1	2	3	4	5
Meter ADD	Function ID	Error code	CRC code low	CRC code high
0x01	0x90	0x02	0xCD	0xC1

Parameters address reflection table

No.	ADD reflection	Variable name	Byte length	Value range	Read write allowed	Remark	
0	0x0000	1st alarm value AL1	2	-1999~9999	R/W		
1	0x0002	1st alarm hysteresis HY1	2	-1999~9999	R/W		
2	0x0004	2nd alarm value AL2	2	-1999~9999	R/W		
3	0x0006	2nd alarm hysteresis HY2	2	-1999~9999	R/W		
4	0x0008	Current rate CT	2	0.000~9999	R/W		
5	0x000A	Analog high limit RH	2	-1999~9999	R/W		
6	0x000C	Analog low limit RL	2	-1999~9999	R/W		
7	0x000E	Voltage corrected value VPS	2	-1999~9999	R/W		
8	0x0010	Current corrected value APS	2	-1999~9999	R/W		
9	0x0012	Voltage span FSV	2	0.000~9999	R		
10	0x0014	Current span FSA	2	0.000~9999	R		
11	0x0016	Voltage value V	2	0.000~9999	R		
12	0x0018	Current value A	2	0.000~9999	R		
13	0x001A	Power factor PF	2	-1.0~1.0	R		
14	0x001C	Active power W	2	0.000~9999	R		
15	0x001E	Reactive power Q	2	0.000~9999	R		
16	0x0020	Apparent power S	2	0.000~9999	R		
17	0x0022	KWh	2	0.000~9999	R		
Reserve							
	EU801	EU901					
18	0x0028		2nd line LED display	1	0~6	R/W	Note①
19	0x0029	0x0028	1st alarm model Ad1	1	0~13	R/W	Note②
20	0x002A	0x0029	2nd alarm mode Ad2	1	0~13	R/W	Note②
21	0x002B	0x002A	1st alarm delay ALT1	1	0~255	R/W	

22	0x002C	0x002B	2nd alarm delay ALT2	1	0~255	R/W	
23	0x002D	0x002C	Analog mode brM	1	0~5	R/W	Note③
24	0x002E	0x002D	Menu lock code LCK	1	0~255	R/W	
25	0x002F	0x002E	Boad rate bAd	1	0~1	R	Note④
26	0x0030	0x002F	Meter address Add	1	0~255	R	
27	0x0031	0x0030	Measure indication	1	0~255	R	Note⑤
28	0x0032	0x0031	Meter description	1	0xD8	R	

R:Read; R/W:Read and Write

Note①:2nd line parameters display

7	6	5	4	3	2	1	0
	W	KWh	PF	A	VA	V	var

Note②:Alarm mode

Upper limit alarm	Communication value	Lower limit alarm	Communication value	Alarm item
VH	0	VL	1	Voltage
AH	2	AL	3	Current
PFH	4	PFL	5	Power factor
P-H	6	P-L	7	Active power
Q-H	8	Q-L	9	Reactive power
S-H	10	S-L	11	Apparent power
KWhH	12	KWhL	13	Kwh

Note③:Analog mode

Communication value	0	1	2	3	4	5
Menu display	V	A	PF	P (KW)	Q (KVAR)	S (KVA)
Analog item	Voltage value	Current value	Power factor	Active power	Reactive power	Apparent

Note④:Baud rate

Communication value	0	1
Menu display	4.8	9.6

Note⑤:Measure indication

D7	D6	D5	D4	D3	D2	D1	D0
AL2	AL1	var	V	VA	A	PF (KWh)	W

The program of achieving 16 bit CRC check code

```

unsigned int Get_CRC(uchar *pBuf, uchar num)
{
    unsigned i, j;
    unsigned int wCrc = 0xFFFF;
    for(i=0; i<num; i++)
    {
        wCrc ^= (unsigned int) (pBuf[i]);
        for(j=0; j<8; j++)
        {
            if(wCrc & 1) {wCrc >>= 1; wCrc ^= 0xA001; }
            else
                wCrc >>= 1;
        }
    }
    return wCrc;
}

```