

EU9L Series One Phase Intelligent Energy Meter User Manual



This series meters are widely applied to control system, SCADA system and energy management system, transformer substation automation, distributing net automation, residence community electrical power monitor, industrial automation, intelligent construction, intelligent switchboard, switch cabinet, etc. It is easy to install and maintain, simple connection, programmable setting parameters on meters or computer.

Features:

- Measuring Items: single phase Voltage/Current/Active Power/Reactive Power/Frequency/Power Factor , Kwh ,Kvarh ect.
- Two switch input and two switch output (4 switch input can be ordered)
- True effective value measurement
- With RS485 interface, Modbus RTU communication protocol
- One active energy pulse output
- With Power fail memory function for Kwh / KvarH

 **Warning** An accident may happen and product may be damaged if the operation does not comply with the instruction

Model

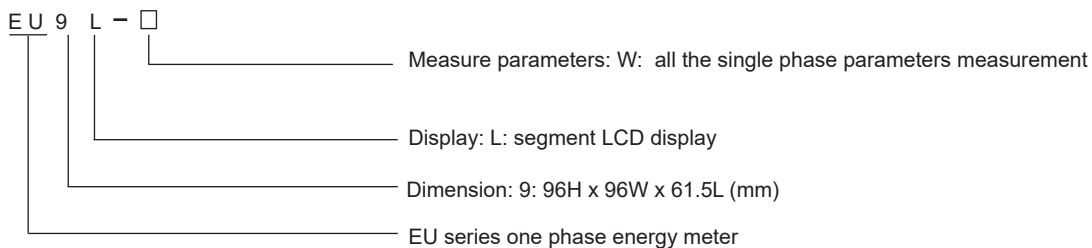

Model Indication

Model	Alarm or remote control	Communication	Switch input or output
EU9L-W	2	RS485	2
EU9L- P	2	RS485	2
EU9L- S	2	RS485	2

Main Technical Parameters

Connection	1 phase 2 wire
Voltage range	AC 220V
Voltage overload	Continuous: 1.2 times Instantaneous: 2 times/10S
Voltage consumption	<1VA (each phase)
Voltage impedance	≥300KΩ
Voltage accuracy	RMS measurement, accuracy class 0.5
Current range	AC 0.025~5A
Current overload	Continuous: 1.2 times Instantaneous: 10 times/10S
Current consumption	<0.4VA (each phase)
Current impedance	<20mΩ

Current accuracy	RMS measurement, accuracy class 0.5
Frequency	45~60Hz, accuracy 0.01Hz
Power	Active / Reactive / Apparent power, accuracy 0.5 class
Energy	Active Energy 1 class, Reactive Energy 2 class
Display	LCD display (optional blue backlight, default white backlight)
Power supply	AC/DC 100~240V (85~265V)
Power supply consumption	≤5VA
Output digital interface	RS-485, MODBUS-RTU Protocol
Pulse output	1 energy pulse output (The light coupling output of open-collector) Pulse constant 3200imp/kWh
Switch Input	2 switch input (Dry contact mode)
Alarm output	2 switch output, 250VAC/3A or 30VDC/5A
Working environment	Temperature: -10~50°C Humidity:<85% RH; Non-corrosive Gas; altitude ≤2500m
Storage environment	-40~70°C
Withstand voltage	Power supply and 485 interface, DI interface, pulse output interface≥DC 2000V
Isolation	Input/ Output/ Power supply to meter cover>5MΩ
Dimension	96W×96H×61.5L(mm)
Weight	0.6kg

■ Panel Indication

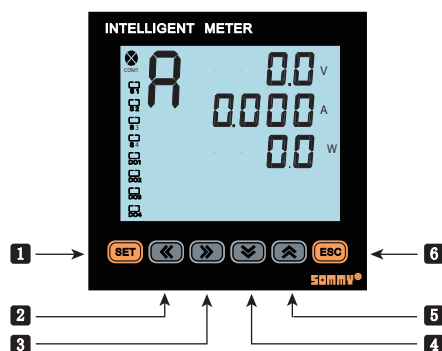

Item	Symbol	Name	Function
1	SET	Set Key	△ Press this key for 5s to enter the menu △ To confirm the modified menu value
2	⏪	Left Key	△ Shift menu and move data position in menu operation △ To shift measure interface outside of the menu
3	⏩	Right Key	△ Shift menu and move data position in menu operation △ To shift measure interface outside of the menu
4	⏴	Decrease Key	△ Enter data modification in menu operation △ To shift energy page outside of the menu
5	⏵	Increase Key	△ Enter data modification in menu operation △ To shift energy page outside of the menu
6	ESC	Return Key	△ For backspace in menu operation △ Back to previous menu

Indication of checking the measure value and meter working status:

- Under Measure Status, Press “⏪ / ⏩” key to switch the display of voltage, current, active power, reactive power, power factor, kwh, Kvarh ect,
- Press “⏴ / ⏵” key to switch display the forward Kwh, backward Kwh, forward Kvarh, and backward Kvarh.
- DO1, DO2
 - Under Alarm Mode: used as alarm output status indicate;
 - Under switch remote control model: used as switch output status indicate;
- S1, S2, as switch remote control input status indicate; 2 switch input as default
- COM flashing means communicate is acting.
- P(Kwh) means Total Active Energy (algebraic sum of forward active energy and backward active energy); Q(Kvarh) means Total Reactive Energy (algebraic sum of forward reactive energy and backward reactive energy).

Illustration for measure interface switch procedure:

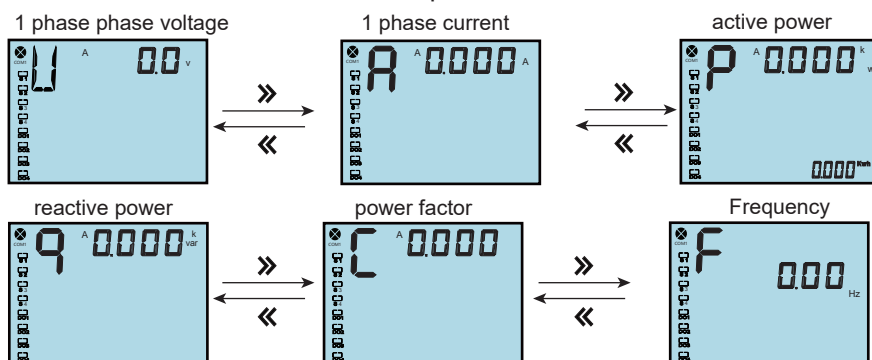

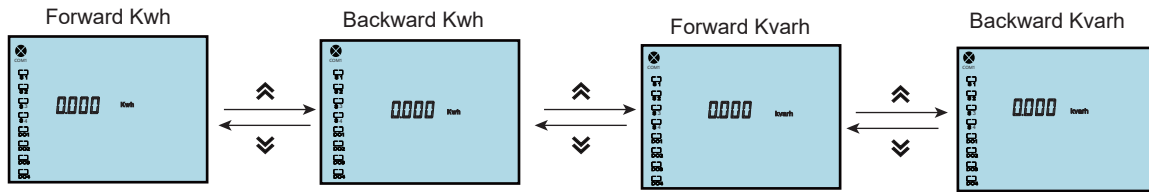

■ Operation Sequence

After modifying data, press SET to confirm or press ESC to return to previous menu

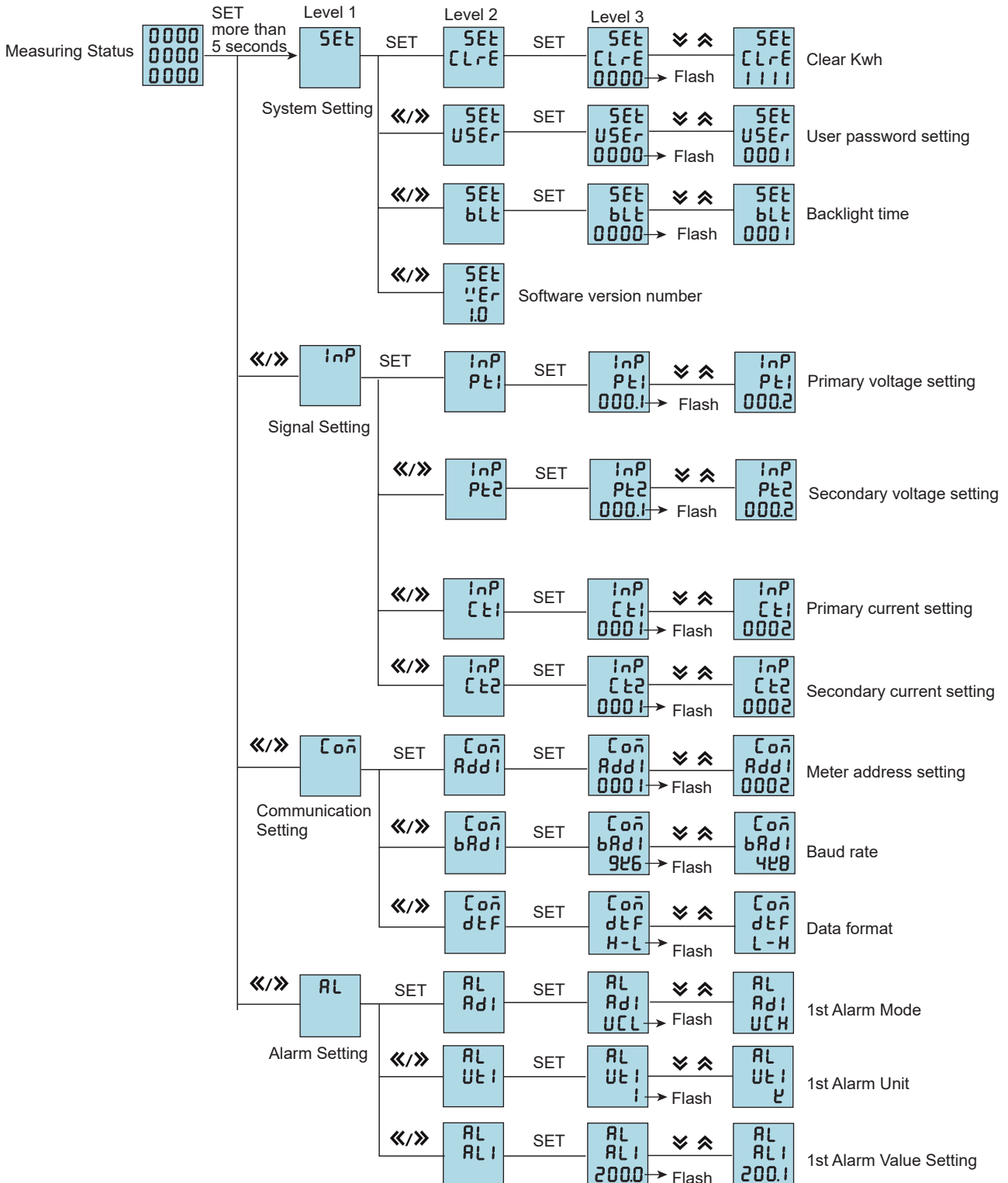

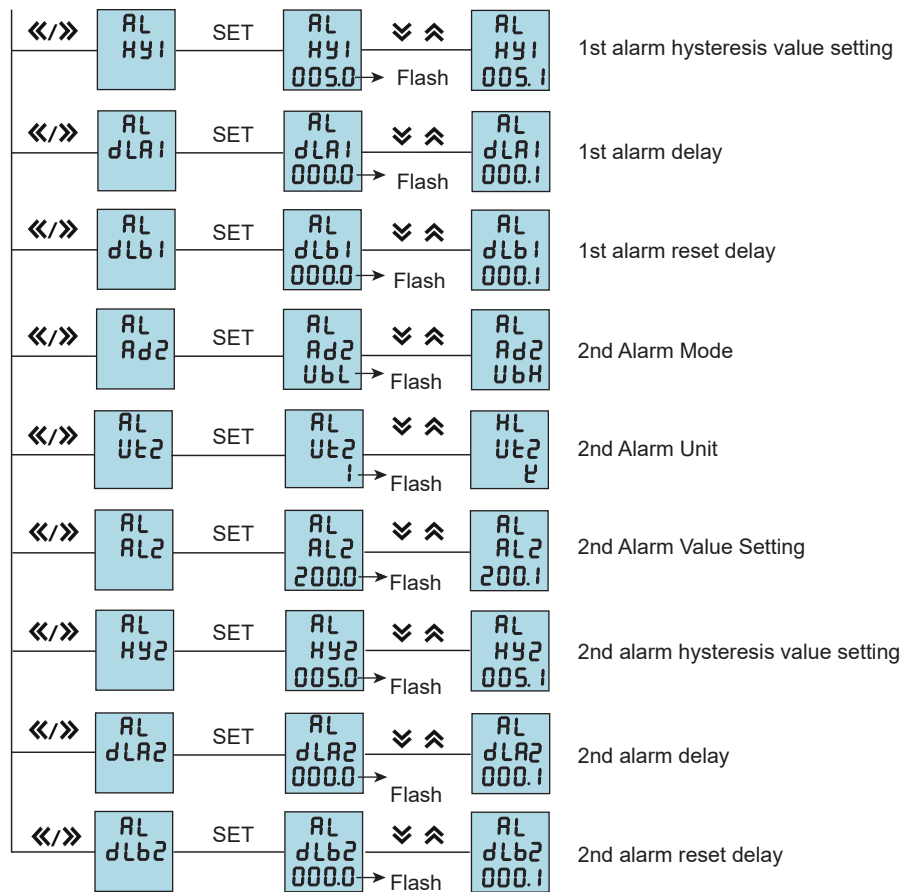

Menu Modification Illustration

Under User Menu Status

1. Press SET Key more than 5 seconds, if setting password, it will pop up a dialog box, input the correct password to enter into user menu, to modify parameter.
2. If the present display is 1st level, press SET Key enter into next level display, press “◀” “▶” key to change menu subitems.
3. If the present display is 2nd or 3rd level, press ESC Key, return to previous display.
4. If present display is 3rd level, press “▼”, “▲” to flash the digit, press“◀”, “▶” to move position , press“▼”, “▲” Key to modify value; press SET Key to save setting value when flashing; if press ESC Key, setting value will not be saved and return to the 2nd level display.
5. After modifying the parameters, press SET Key more than 5 seconds or press ESC Key to exit user menu and enter into measuring status.

Menu Structure and Function Description

No	1st Level	2nd Level	3rd Level	Description
1	SEt System setting	Clear Energy CLrE	0000	When input 1111, user can clear energy ; When input 1234, the menu can be reset to default setting.
		User Password USEr	0000	modify password, factory default setting 0000, no password
		Backlight time bLt	0000	backlight lighting delay time, unit “second”. When value is “0” , it will keep on lighting all the time
		Software Version VER	1.0	Software version, read only
2	InP Signal Setting	Voltage transform Pt1	0.1-500.0	Primary voltage, unit KV
		Voltage transform Pt2	0.1-500.0	Secondary voltage, unit KV
		Current transform Ct1	1-9999	Primary current, unit A
		Current transform Ct2	1-9999	Secondary current, unit A
3	Coñ Communication Setting	Address Add1	1-247	Meter address range
		Baud rate brd1	1k2 / 2k4 / 4k8 / 9k6	Baud Rate 1k2 means 1200, 2k4 means 2400, 4k8 means 4800, 9k6 means 9600
		Data sequence dtF1	H-L / L-H	high register is in front or low register is in front

Menu Structure and Function Description

No	1st Level	2nd Level 2	3rd Level	Description
4	AL Alarm setting	Alarm mode Ad1	1-62	When value is DO, it is remote control mode, otherwise it is alarm mode, please refer to Table 1 as below
		Alarm value unit Ue1	1/ K/ M	1: means international standard unit, K: 1000 times of international standard unit, M: 1000000 times of international standard unit.
		Alarm value AL1	0-9999.9	1st alarm value setting (unit is standard display unit)
		Alarm hysteresis value HY1	0-9999.9	1st alarm hysteresis value setting (unit is standard display unit)
		Alarm delay dLA1	0-9.9	Alarm action delay time, unit: second
		Alarm reset time dLb1	0-9.9	Alarm action reset time, unit: second
		Alarm mode Ad2	1-62	When value is DO, it is remote control mode, otherwise it is alarm mode, please refer to "Table 1"
		Alarm value unit Ue2	1/ K/ M	1: means international standard unit, K: 1000 times of international standard unit, M: 1000000 times of international standard unit.
		Alarm value AL2	0-9999.9	2nd alarm value setting (the unit is standard display unit)
		Alarm hysteresis value HY2	0-9999.9	2nd alarm hysteresis value setting (unit is standard display unit)
		Alarm delay dLA2	0-9.9	Alarm action delay time, unit: second
		Alarm reset time dLb2	0-9.9	Alarm action reset time, unit: second

■ Output function

1. Remote control function: S1-S2 is used to remote control Electric switch status. Two DO1, DO2 function be used to control electric devices; when using this function, alarm mode should be setted as "0", otherwise, DO1, DO2 will be as AL1, AL2 output; DO1, DO2 control function is written via RS485 interface.
3. Communication function (please refer to Communication protocol)
4. Alarm fnction, after the meter is powered on and run steady more than 5 seconds, alarm begin to work. (Please refer to table 1)

■ Communication protocol

I. MODBUS serial communication protocol basic rules

1. The meter adpots Modbus RTU communication protocol,RS485 half duplex communication,read function code 0x03, write function code 0x10, adpots 16 digit CRC check,the meter does not return for error check.

Data frame format:

Start bit	Data bit	Stop bit	Check bit
1	8	1	No

- (1) All the RS485 communication should comply with host/slave method. Under this method, information and data is transmitted between one host and maximum 32 slaves (monitoring equipment);
 - (2) Host will initialize and control all information transmitted in RS485 communication circuit.
 - (3) In any case, communication can never be started from a slave.
 - (4) All the RS485 communication is sending by packet . One data packet is a simple string (every string has 8 bit). One packet include 128 byte at most. The bytes in the packet formed in standard asynchronous serial data , and transmitting in the mode of 8 data bits, 1 stop bit, no check bit.
 - (5) Host sending is called request, slave sending is called response.
 - (6) In any case, slave can only respond to one request of host.
2. Each MODBUS data packet is consisted several parts as below:
 - (1) Slave address; (2) Function code to be executed; (3) Register address (variate address); (4) Data; (5) CRC check;
 - (1) Slave address: address length is 1 byte, effective slave address range is 1-247, if slave receives a data packet, whose frame address information is consonant with its own address information , it will execute the order of data packet.
 - (2) Function code length in MODBUS data packet is one byte, used to inform the slave what kind of operation needs to be executed. The slave response data packet should have the same function code byte of the operation requested by host.

Please refer to below table for related function code:

Function code	Meaning	Function
0x03	Read register	Read one or more present register value
0x06	Write single-register	Write specified value into one internal register
0x10	Write multi-register	Write specified value into several internal registers (Factory default write single register)

- (3) Register address variable: data area storage location when slave executes effective order. Different variable seizes differents numbers of register, some address variable seizes two register, 4 byte data, somevariable seizes one register, 2 byte data, please use according to actual situation.
- (4) Data area: data area includes the data required by terminal to execute specified function or collected data when terminal respond to query. The content of the data could be numerical value, reference address or set value; for example: function code tells terminal to read a register, data area needs to indicate which register to started from and how much data to be read, embedded address and data will be different according to different content between type and slave; register numerical value send sequence : high byte in the front, low byte in the back.
- (5) CRC check: MODBUS-RTU mode adopts 16 bit CRC check. Sending equipment should do CRC16 calculation for each data of packet, final result is stored in check area. Receiving equipment also make CRC16 calculation for each data of packet (except check area), and compare result area with check area; only the same packet can be accepted, for the specific CRC check algorithm please refer to appendix.

II. Network time consideration

Transmitting package in RS485 network should follow the time regulation as follows:

- When baud rate set as 9600, the delay time between two host request is recommended to be 300ms or more, lesser time may cause the loss of data packet.
- When the recommended baud rate is 9600, if use smaller baud rate, please enlarge delay time properly. For example, when baud rate is 2400, two request should be set as more than 500ms.

III. Abnormal communication processing

If host send a illegal data packet or host request a invalid data register, abnormal data response will happen. This abnormal data response is consisted of slave address, function code, error code and check area. When the high bit position of function code area is 1, it means the present data frame is abnormal response.

Below table illustrates the meaning of abnormal function code:

According to MODBUS communication requirement, abnormal response function code=request function code+0x80; when abnormal response, put 1 on the highest bit of function code. For example: if host request function code is 0x04, slave response function code is 0x84.

Error code type	Name	Contents illustration
0x01	Function code error	Meter received the unsupported function code
0x02	Variable address error	Data location designated by host exceeds range of meter, or receive illegal register operation.
0x03	Variable value error	Data value sent from host exceeds the corresponding data range of meter, or data structure is incomplete

IV. Communication frame format illustration

1. Read multi-register

For example, host reads UA (A phase voltage), suppose measured A phase voltage is 220.0V.

The address code of UA is 0x4000, because UA is fixed data (4 byte), seizes 2 data register, the hexadecimal data of 220.0V is 0x0000898 (2200).

Host request

Slave address	Read function code	Register address (variable)		Register quantity		CRC check code	
1	2	3	4	5	6	7	8
Meter address	Function code	Start address high bit	Start address low bit	High bit	Low bit	CRC code low bit	CRC code high bit
0x01	0x03	0x40	0x00	0x00	0x02	0xD1	0xCB

Slave normal answers (high bit is in front)

Slave address	Read function code	Byte number (2 times of register quantity)	Register data		Register data		CRC check code	
1	2	3	4	5	6	7	8	9
Meter address	Function code	Data byte length	Data 1 high bit	Data 1 low bit	Data 2 high bit	Data 2 low bit	CRC code low bit	CRC code high bit
0x01	0x03	0x04	0x00	0x00	0x08	0x98	0xFC	0x59

Slave normal answers (low bit is in front)

Slave address	Read function code	Byte number (2 times of register number)	Register data		Register data		CRC check code	
1	2	3	4	5	6	7	8	9
Meter address	Function code	Data byte length	Data 2 high bit	Data 2 low bit	Data 1 high bit	Data 1 low bit	CRC code low bit	CRC code high bit
0x01	0x03	0x04	0x08	0x98	0x00	0x00	0x79	0xBC

Function code abnormal answer: (For example, host request function code is 0x04).

Slave abnormal answers (Read multi-register)				
1	2	3	8	9
Meter address	Function code	Error code	CRC code low bit	CRC code high bit
0x01	0x84	0x01	0x82	0xC0

For example: When present measured current value is: Ia=100 A, Ib=200 A, Ic=300 A, separately read three current value at a time. Host send read 01 address meter, read the current value data started from 400C (A phase current) register. Hexadecimal code of 100.000 is 000186A0; hexadecimal code of 200.000 is 00030D40; hexadecimal code of 300.000 is 000493E0; data adopts the 32-bit unsigned data representation, with three decimal point. For example, if data value is 12345, the actual value is 12.345.

Host send

Meter address	Function code	Address		Register quantity		CRC check code	
01	03	40	0C	00	06	10	0B

Meter return

Meter address	Function code	Read byte number	Data 1				Data 2				Data 3				CRC check code	
01	03	0C	00	01	86	A0	00	03	0D	40	00	04	93	E0	8F	1D

2. Write single-register

For example: Host writes fixed data, 1st alarm mode is AD1.

Suppose the address code of AD1 is 0x49901, because AD1 is fixed data, seizes 1 data register, decimalist code of 11 is 0X000B.

Host request (Write single-register)

Slave address	Write function code	Register address (variable)		Register number		Byte number (2 times of register number)	Register data		CRC check code	
1	2	3	4	5	6	7	8	9	10	11
Meter address	Function code	Start address high bit	Start address low bit	High bit	Low bit	Data byte length	Data 1 high bit	Data 1 low bit	Data 2 high bit	Data 2 low bit
0x01	0x06	0x49	0x00	0x00	0x01	0x02	0x00	0x0B	0xBE	0x75

Slave normal answer (Write single-register)

Slave address	Write function code	Register address (variable)		Register number		CRC check code	
1	2	3	4	5	6	7	8
Meter address	Function code	Start address high 8 bit	Start address low 8 bit	High bit	Low bit	CRC code low bit	CRC code high bit
0x01	0x06	0x49	0x00	0x00	0x01	0x5E	0x56

2. Write multi-register

For example: Host writes fixed data, 1st alarm mode is AD1.

Suppose the address code of AD1 is 0x4800, because AD1 is fixed data, seizes 1 data register, decimalist code of 11 is 0X000B.

Host request (Write multi-register)										
1	2	3	4	5	6	7	8	9	10	11
Meter address	Function code	Start address high bit	Start address low bit	Data byte length high bit	Data byte length low bit	Data byte length	Data 1 high bit	Data 1 low bit	CRC code low bit	CRC code high bit
0x01	0x10	0x49	0x00	0x00	0x01	0x02	0x00	0x0B	0x3F	0x53

Slave normal answer (Write multi-register)							
1	2	3	4	5	6	7	8
Meter address	Function code	Start address high 8 bit	Start address low 8 bit	Data byte length high bit	Data byte length low bit	CRC code low bit	CRC code high bit
0x01	0x10	0x49	0x00	0x00	0x01	0x17	0x95

Data position error answer:(For example, host request write address index is 0x0050).

Slave abnormal answer (Write multi-register)				
1	2	3	4	5
Meter address	Function code	Error code	CRC code low bit	CRC code high bit
0x01	0x90	0x02	0xCD	0xC1

ES9L parameter address reflection table
 Note: address code is the index of variable array

No.	Address reflection	Variable name	Register number	Data type	Read / Write	Data conversion explain
1	0x4000	voltage	2	long	R	0.1V Note ⑥
2	0x400c	current	2	long	R	0.001A Note ⑥
3	0x4012	Active power	2	long	R	0.001KW Note ⑥
4	0x401a	Reactive power	2	long	R	0.001Kvar
5	0x4022	Apparent power	2	long	R	0.001KVA Note ⑥
6	0x402a	Power factor	2	long	R	0.001 Note ⑥
7	0x4032	Frequency	2	long	R	0.01Hz Note ⑥
8	0x4034	Total Kwh	2	long	R	0.001kWh
9	0x4038	Forward Kwh	2	long	R	
10	0x403a	Backward Kwh	2	long	R	
11	0x4036	Total Kvarh	2	long	R	0.001kvarh Note ⑥
12	0x403c	Forward Kvarh	2	long	R	
13	0x403e	Backward Kvarh	2	long	R	
14	0x4800	Voltage transform PT1	2	long	R/W	0.001 Note ⑥
15	0x4802	Voltage transform PT2	2	long	R/W	
16	0x4804	Current transform CT1	2	long	R/W	
17	0x4806	Current transform CT2	2	long	R/W	
18	0x4808	1st alarm value	2	long	R/W	
19	0x480a	1st hysteresis value	2	long	R/W	
20	0x480c	2nd alarm value	2	long	R/W	
21	0x480e	2nd hysteresis value	2	long	R/W	
Reserve						
22	0x4900	1st alarm mode value (Please refer to table 1)	1	int	R/W	No decimal point
23	0x4901	1st alarm unit Note③	1	int	R/W	
24	0x4902	1st alarm operation delay	1	int	R/W	
25	0x4903	1st alarm cutting delay	1	int	R/W	
26	0x4904	2nd alarm mode value (Please refer to table 1)	1	int	R/W	
27	0x4905	2nd alarm unit Note③	1	int	R/W	
28	0x4906	2nd alarm operation delay	1	int	R/W	
29	0x4907	2nd alarm cutting delay	1	int	R/W	
Reserve						
30	0x4a01	Communication address	1	int	R	No decimal point
31	0x4a02	Baud rate Note②	1	int	R	
32	0x4a03	Data format	1	int	R	
33	0x4a07	switch output (alarm status available) Note④	1	int	R	
34	0x4a08	switch input Note⑤	1	int	R	
35	0x4a09	Remote control input	1	int	R/W	
36	0x4a0a	Backlight time	1	int	R/W	

Reference table 1: Reference table for alarm output electric parameters

No.	Item	ON/OFF output (low alarm) code	ON/OFF output (high alarm) code
1	Ua voltage	1 (UaL)	2 (UaH)
2	Ia current	17 (IaL)	18 (IaH)
3	Pa active power	25 (PaL)	26 (PaH)
4	Qa reactive power	33 (QaL)	34 (QaH)
5	Sa apparent power	41 (SaL)	42 (SaH)
6	PFa power factor	49 (PFaL)	50 (PFaH)
7	F frequency	57 (FL)	58 (FH)
8	EP (Total active energy)	59 (EPL)	60 (EPH)
9	EQ (Total reactive energy)	61 (EQL)	62 (EQH)

Note②: Baud rate

Communication value	0	1	2	3
Menu display	1K2	2K4	4K8	9K6

Note③: Alarm/Analog Unit

Communication value	0	1	2
Menu display	1	K	M

Note④: Alarm status indication

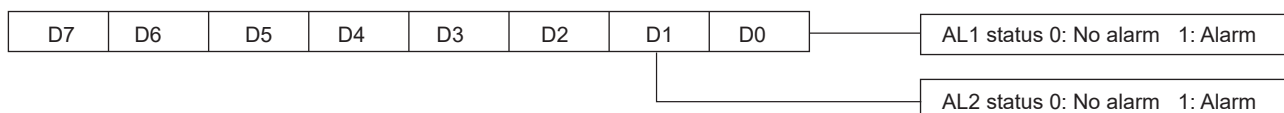

Note⑤: Switch input status indication

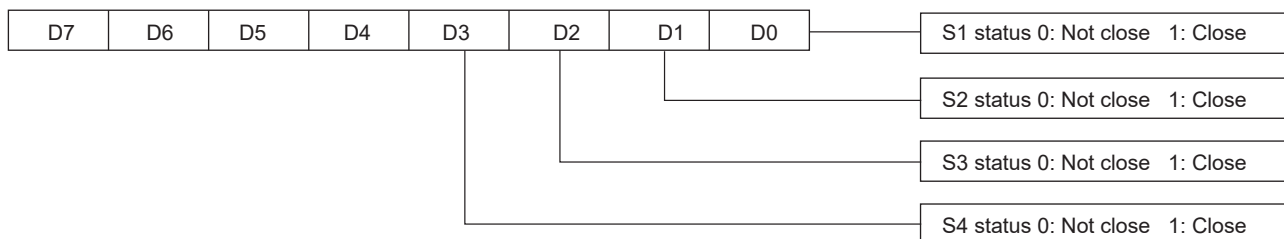

Note⑥: Read out or write in actual value

Read out or write in actual value=communication read out value x unit
 For example: Read out A phase phase voltage, if read out value is 0x00000898,
 corresponding decimal location: 2200, because voltage unit is 0.1V, the actual A phase voltage value is 2200x0.1V=220.0V

The process of generating a CRC: (Can refer to program example as below)

1. Preset a 16 bit register as 0FFFFH(All 1), call it CRC register.
2. Xor the 8 bit of data frame's first byte with the low byte of CRC register, stock the result back to CRC register.
3. Move the decimal point one bit to the right, fill the highest bit with 0, remove and check the lowest bit.
4. If the lowest bit is 0, repeat the third step(next move); if the lowest bit is 1, xor CRC register with a preset fixed value(0A001H).
5. Repeat the third and fourth step till the eighth move. A complete 8 bit has been processed in this way.
6. Repeat the second to fifth step to process the next 8 bit, till all bytes are precessed.
7. Finally the value of CRC register is the value of CRC. Besides, there is another way using the preset form to calculate CRC, its main feather is fast calculating speed, but form needs large storage space. The process of this way please refer to relative material.

```

The program of achieving 16 bit CRC check code
unsigned int Get_CRC (uchar*pBuf,uchar num)
{
    unsigned i,j;
    unsigned int wCrc=0xFFFF;
    for(i=0;i < num;i++)
    {
        wCrc^=(unsigned int)(pBuf[i]);
        for(j=0;j < 8;j++)
        {
            if(wCrc & 1){wCrc > >=1; wCrc^=0xA001;}
            else wCrc > >=1;
        }
    }
    return wCrc;
}
    
```

■ Dimension and Mounting Size

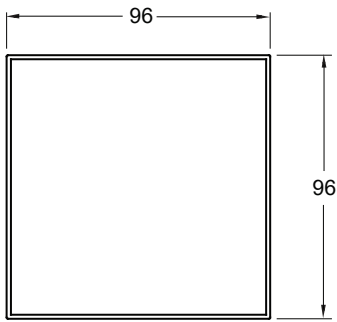

Panel Size

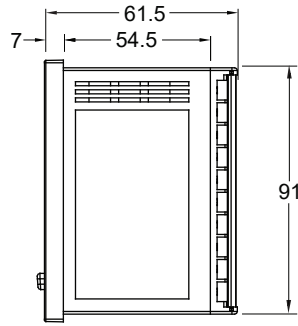

Side-face Size

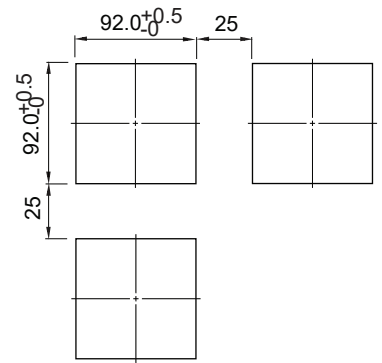

Mounting Size

■ Connection Drawing

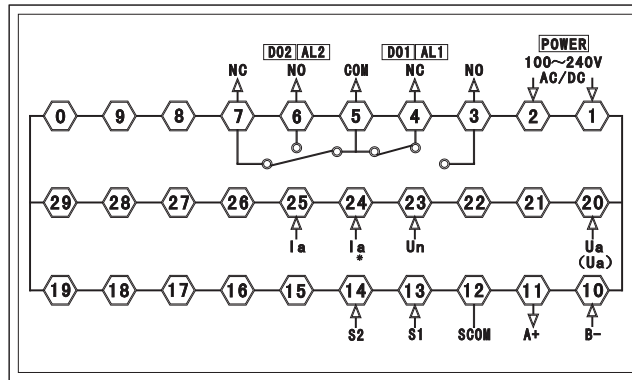

Mode 1 (1 pcs CT): 1 phase wire connection

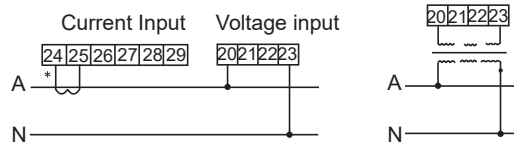

Current input via CT Voltage direct input Voltage input via PT

